

Smart Street Lighting System Using Arduino UNO

Sanjana Mathew¹, Sumedh Reddy K² and Hemlata Dalmia³

^{1,3}Department of ECE, Sreyas Institute of Engg and Tech, Hyderabad

²Software Engineer, Sunera Technologies, Inc, Hyderabad

ABSTRACT

A tremendous boom in the area of Machine-to-Machine communication known as the Internet of Things (IOT) allows the possibility for autonomous devices to use Internet for exchange of information. Internet of Things (IoT) involves connecting physical devices to the internet which provides opportunities to build smart systems or applications. IOT paradigm assumes many devices connected over conventional network. These devices usually have limited resources, so implementing part of the service to a cloud infrastructure is a prominent solution.

This paper presents the design and execution of real time monitoring temperature and humidity in a Telecom network Electronic soft switch rooms. The sensors used to detect/identify unauthorized movement and any person/object being within a certain range to critical network elements and to give an alert when ever any one approaching near by hazardous elements like Battery and Power supply. Maintenance staff have to manually look at it 24X7 and take the necessary steps but by using this design we can reduce working efforts and improve accuracy, stability, efficiency in unmanned timings also.

Arduino UNO is a open-source micro controller board based on the Microchip ATmega328P micro controller and developed by Arduino.cc which is a widely used micro controller. This board consists of sets of digital and analog input/output (I/O) pins that is interfaced to various expansion boards (shields) and other circuits. The board consists of 14 Digital pins and 6 Analog pins. It is programmable with the Arduino IDE (Integrated Development Environment) via a type B USB cable. The board is powered by a USB cable or by an external 9 volt battery, though it accepts voltages between 7 and 20 volts.

Index Terms—Internet of Things (IOT), IDE (Integrated Development Environment).

I. INTRODUCTION

In present scenario humans are too busy and are unable to find time to switch off the lights whenever it's not necessary. Lights are switched on in the evening before the sun sets and they are switched off the next day morning after there is sufficient light on the outside which leads to wastage of power. In order to conserve our environment we need to save power. Lights should be switched on when there is absolute darkness and switched off when not necessary.

This paper gives the best solution for combating wastage of electrical power. Also the manual operation of the lighting system is completely eliminated. The power consumption in entire world is increasing at a faster pace due to population explosion and tremendous economic development but the availability of energy sources remains woefully constrained. Resource augmentation and growth in energy supply has not kept pace with the increasing demand and, therefore, the world continues to face serious energy shortages.

Streetlights are an important part of any developing society. They are present in all major highways and in the suburban areas too. Every day, streetlights are powered from sunset to sunrise at full strength even when there is no one around. Globally millions of dollars are spent each day on these street lights to provide required electrical energy. The maintenance and replacement costs of conventional incandescent bulbs are huge. They consume a lot of electric power to function and also emit tremendous amount of heat. All of this contributes to a higher demand for production of electricity and consequently, more carbon dioxide

emissions from powerhouse. So, along with unnecessary light pollution, they also are a prime source of damage to our Mother Earth too.

The paper discusses about methods which are used for harvesting the energy from renewable energy sources like sun and to effectively use this energy for the benefit of mainly the villagers facing the serious power problems. The main aim of this paper is to provide a "IoT based Smart Street Lighting System". We use the word "Smart" because the system i.e., the Street Lights turns on only when there is darkness around and turns off immediately when sunrises. In this technology no human being is required in order to on and off the street lights. Smart Street Lighting System is a boon for both rural areas and even metropolitan cities for conserving power.

II. PROPOSED METHODOLOGY

Here a smart method is proposed which uses street light automation system based on IOT. In this method street lights are automatically controlled which increases energy efficiency and cost savings of things. This also detects defective street lights and they can be controlled remotely and has a TIMER set too. In traditional systems there is no option of dimming of lights depending upon the presence of objects on the road where as in this smart technology we use a system which will help to save energy as well as cost as shown in Fig 2.1.

The Smart street light control system is based on dynamic control methodology. According to this methodology when it becomes dark, all the street lights automatically glow for a few seconds and switches off. But throughout the night, only one street light remains switched on for security concerns. When a vehicle or a pedestrian passes by, a chain of street lights glows and as the vehicle moves forward, the next chain of lights starts glowing where the previous block switches off.

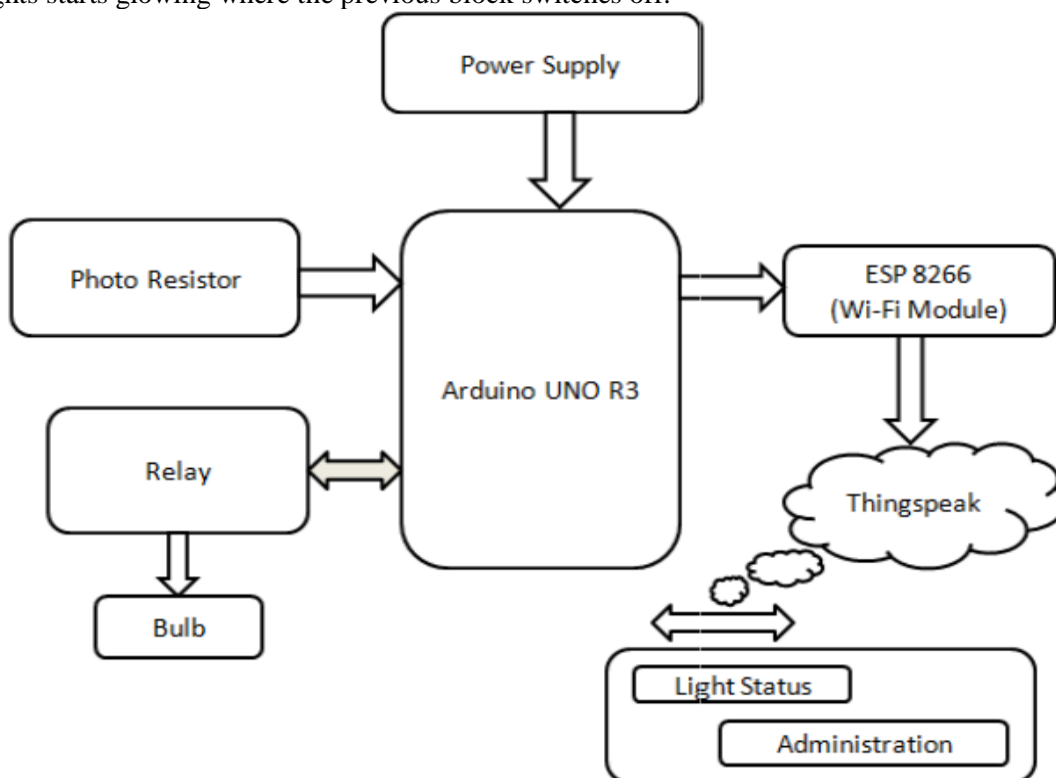

Fig 2.1 Smart Street Light System Using Arduino Uno

2. 1 EXISTING SYSTEM

Industries for street lighting systems are growing rapidly and becoming complex with rapid growth of industries. Automations, Power consumptions and Cost Effectiveness are the important criteria's in the field of electronics and electrical related technologies. To control and maintain complex street lighting system

more economically, various street light control systems are developed. These systems are developed to control and reduce energy consumption of a city's public lighting system using different technologies. The existing work is done using HID lamps. Currently, HID is used for urban street light based on principle of gas discharge, thus the intensity is not controlled by any voltage reduction method as the discharge path is broken.

HID lamps are a type of electrical gas discharge lamp which produces light by means of an electric arc between tungsten electrodes housed inside a translucent or transparent fused quartz or fused alumina arc tube. This tube is filled with both gas and metal salts. The gas facilitates the arc's initial strike. Once the arc is started, it heats and evaporates the metal salts forming plasma, which greatly increases the intensity of light produced by the arc and reduces its power consumption. High-intensity discharge lamps are a type of arc lamp.

2.2 PROPOSED SYSTEM

Since the HID lamps are not cost effective and not reliable, smart street light system has overcome by replacing the HID

lamps with LED lamps. Due to automation, power consumption and cost effectiveness in the present field of electronics and electrical related technologies, an industry for street lighting systems are growing rapidly.

In order to control and maintain complex street lighting system more economically, various street light control systems are developed. These systems are developed to control and reduce energy consumption of a city's public lighting system using different technologies which uses IR motion sensors to detect the movement of vehicles after which the street light begins to glow. As the vehicle moves, the street light that was glowing switches off and the following lights begins to glow.

A) ARDUINO UNO R3

Arduino UNO R3 specifications are ATmega328 microcontroller, operating voltage at 5v, input voltage 7 to 12v, input voltage limit up to 20v, digital I/O pins 14, analog pins 6, DC current 40mA, flash memory 32KB including 0.5KB used by boot loader. SRAM of 2KB, EEPROM of 1KB and clock speed of 16 MHz. Some of the Features of Arduino UNO are power can be USB connection or external power supply, with 7 to 12 volts recommended. The Arduino UNO provides power pins for other devices, the variants are 5V, 3.3V and Vin IOREF pin for optional power.

Arduino UNO is basically a 2KB of SRAM and 1KB of EEPROM (Electrically Erasable Programmable Read Only Memory). There are various input and output pins where 14 of them are digital pins with serial transfer and external interrupts and PWM (Pulse Width Modulation) pins and 6 analog pins.

B) INFRARED SENSOR

An infrared sensor is an electronic device that emits in order to sense some aspects of the surroundings. An IR sensor can measure the heat of an object as well as detects the motion. These types of sensors measures only infrared radiation, rather than emitting it that is called as a passive IR sensor. Usually in the infrared spectrum, all the objects radiate some form of thermal radiations. These types of radiations are invisible to our eyes that can be detected by an infrared sensor. The emitter is simply an IR LED and the detector is simply an IR photodiode which is sensitive to IR light of the same wavelength as that emitted by the IR LED. When IR light falls on the photodiode. the resistances and the output voltages, changes in proportion to the magnitude of the IR light received.

2.3 WORKING

Street light Automation system has a battery in the transmission side, it also has PIR LDR sensors Arduino UNO board with a Wi-Fi modem of range 2.4 gigahertz and in the receiver side it has another modem connected to a system with a same range. It has electrical power supply and the Arduino kit is directly connected to the street light arrays

> replace this line with your paper identification number (double-click here to edit) < 3

1. Hardware arrangements: first connect the required equipments (ldr pir wifi and other resistors) to the bread board.
2. Software and hardware connection: connect the breadboard to the arduino uno which is further connected to the system having arduino uno ide to upload the source code.
3. Testing: the source code is compiled and then we run it.
4. Connection to internet: connect the internet of the system to the blynk an android platform which helps in controlling the lights remotely. Note that both the android device and the system should have internet connections.

The working procedure of the Smart street light using IR sensors is explained below. The following are the different steps included in building a Smart street light.

- LDR pin 1 is connected to A0 (analog) port of Arduino Uno board.
- Connect all the IR sensors to port numbers 2, 3, 4, 5 and 6 respectively (digital) which is the input signal to the Arduino board.
- Connect the ground of all the sensors to GND port.
- The LED's which are the output signals, are connected to port number 8, 9, 10, 11 and 12 respectively.
- Again connect the ground of all the sensors to GND port. 6. Power is passed to the Arduino (7-12V).

Smart Street Light System works in accordance with the varying sunlight. Whenever there is sufficient sunlight in surroundings, LDR exhibits high resistance and acts as an insulator, while in darkness this LDR behaves as low resistance path and allows the flows of electricity, this LDR's operates with the help of IR sensors, these sensors are activated under low illumination conditions and these are controlled by an AT89C51 micro controller, every basic electronic circuit will operate under regulated 5v DC, so need to step down the 230v AC into 12v AC by means of an step down transformer, this 12v AC is to converted into 5v DC by using an bridge rectifier, and the controlled output from the voltage regulator is sent to the operational kit.

The heart of Arduino circuit is the low power, high performance Arduino micro controller is programmed by embedded assembly programming language for implementing these tasks; this program is stored and operated by means of storage device EPROM, while coming to the functional block i.e. LDR, these LDR's are in expensive, smaller in size, less complexity, highly reliable, low power applications, minimum risk with greater accuracy. The project is successfully implemented in many areas based on the experimental verification proving that it can save the electrical power to greater extent removing the manual work completely; the system became the origin for upcoming advanced intelligent systems in saving both human and electrical power.

A. ABBREVIATIONS AND ACRONYMS

PIR (Passive Infrared Sensor), LDR (Light Dependent Resistor).

III. RESULT & DISSCUSSION

The project aims were to reduce the side effects of the current lighting system and find a solution to save power. In this project the first thing to do is to prepare the inputs and outputs of the system to control the lights. The project shown in the Fig 3.1 has been implemented and works as expected and will prove to be very useful.



Fig 3.1 Output Chart Obtained in Thingspeak

Each of the dots corresponds to the value and the time at which the value was posted to the channel. Place the mouse over a dot to get more details on the exact date and the GMT offset from which the value was posted.

Please note that in the above example, I have sent some sample values to the channel. You can send any data here, say the periodic readings from a temperature sensor or RPM values from a motor. The Y-axis shows the names that we specified to each of the labels.

A. CHALLENGES:

- Switching of LED Strip based on voltage supply.
- Interfacing of Arduino to the web browser.
- Displaying serial monitor data of Arduino onto the web browser.

> REPLACE THIS LINE WITH YOUR PAPER IDENTIFICATION NUMBER (DOUBLE-CLICK HERE TO EDIT) < 4

- Fixing the range of LDR.

B. LIMITATIONS:

- Delay in displaying the data on web browser.
- Variation Input voltage.
- The sensors used are not suitable for real life setup.
- Power LED should be of greater voltage for actual setup.

C. ADVANTAGES OF PROPOSED SYSTEM:

- Automatic switching of street lights
- Maintenance cost reduction
- Reduction in CO₂ emission
- Reduction of light pollution
- Wireless communication
- Energy saving
- Reduction of manpower

IV. CONCLUSION AND FUTURE SCOPE

The above project i.e. Smart Street-Light System with IoT can be powered from a battery. The AC voltage can be stepped up and given to the electric grid. The AC voltage from the electric grid can be stepped down,

rectified and used for powering the circuit. Meanwhile, the street light can also be powered by the A.C. voltage, which is controlled by a relay switch connected to the switching part of the circuit. The above-mentioned strategy will enable in an effective way for the operation of the circuit and for powering the street light also. Using this smart project, we can also estimate the speed of the vehicle, recognizing the number plate, recognizing the accidents took place on roads etc if needed. This Smart Street light project not only helps in rural areas but also beneficial in urban areas too. As we are moving towards more advancement, we require more power so use of renewable resources is useful and advantageous. With this project, we can even add smart parking of vehicle and it is even useful for driverless cars.

This project has a bright future not only to save power but also reduced the calamities and even reduced the crime rate. The use of power electronics is increasing exponentially across various sectors of human life. The components used in this method, like Arduino and sensors are slowly becoming an integral part of our daily routines. So, it is only fitting that we use them to improve efficiency in every walk of life. Keeping in mind the importance of energy conservation, Smart Street Light System with IoT is an excellent and effective method. It combines safe lighting protocols with consumption of less amount of power. The energy savings, as discussed before are impressive. The future scope of this project expands into speed detection and customizable area of illumination.

An additional component which would lead to better functioning of the concept would be the usage of LED bulbs. Despite their high costs, they are best option as they drastically reduce the power consumption. They will aid in further saving of energy and reduction in operational costs.

REFERENCES

- 1) Archana. G, Aishwarya N, Anitha J “Intelligent Street Light System” International Journal of Recent Advances in Engineering & Technology, Vol-3, Issue-4, 2015.
- 2) K. S. Sudhakar, A. A. Anil, K. C. Ashok and S. S. Bhaskar, Automatic Street Light Control System, International Journal of Emerging Technology and Advanced Engineering, Vol. 3, May 2013.
- 3) M. Abhishek, S. A. Shah, K. Chetan and K. A. Kumar, “Design and implementation of traffic flow based street light control system with effective utilization of solar energy,” Int. J. Sci. Eng. Adv. Technol., vol. 3, no. 9, pp. 195-499, 2015.
- 4) Oditis and J. Bicevskis, “The concept of automated process control,” Sci. Pap., vol. 756, pp. 193–203, 2010.
- 5) Adetiba, V. O. Matthews, A. A. Awelewa, I. A. Samuel and J. A. Badejo, “Automatic electrical appliances control panel based on infrared and Wi-Fi: A framework for electrical energy conservation,” Int. J. Sci. Eng. Res., vol. 2, no. 7, pp. 1-7, July.2011.
- 6) S. A. E. Mohamed, “Smart street lighting control and monitoring system for electrical power saving by using VANET,” Int. J. Commun. Network Syst. Sci., vol. 6, pp. 351-360, 2013.
- 7) S. Jalan, “A survey on automatic street lightning system on indian streets using Arduino,” Int. J. Innovative Res. Sci. Eng. Technol., vol. 6, no. 3, pp. 4139-4144, 2017.
- 8) Benet, F. Blanes, J.E. Simó and P. Pérez, “Using infrared sensors for distance measurement in mobile robots,” Rob. Auton. Syst., vol. 40, no. 4, pp. 255-266, 2002.
- 9) L. Louis, “Working principle of arduino and using it as a tool for study and research,” Int. J. Control Autom. Commun. Syst., vol.1, no.2, pp. 21-29, 2016.
- 10) > REPLACE THIS LINE WITH YOUR PAPER IDENTIFICATION NUMBER (DOUBLE-CLICK HERE TO EDIT) < 5
- 11) Jalan, G. Hoge, S. Banaitkar and S. Adam, “Campus automation using arduino”, Int. J. Adv. Res. Electr. Electron. Instrum. Eng., vol. 6, no. 6, pp. 4635- 4642, 2017. [8] H. Satyaseel, G. Sahu, M.

- Agarwal and J. Priya, "Light intensity monitoring & automation of street light control by Iot," *Int. J. Innovations Adv. Comput. Sci.*, vol. 6, no. 10, pp. 34-40, 2017.
- 12) S. Srivastava, "Automatic street lights," *Adv. Electron. Electr. Eng.*, vol. 3, no. 5, pp. 539-542, 2013.
 - 14) Rao and A. Konnur, "Street light automation system using arduino uno," *Int. J. Innovative Res. Comput. Commun. Eng.*, vol. 5, no. 11, pp. 16499-16507, 2017.
 - 15) M. Abhishek, S. A. Shah, K. Chetan and K. A. Kumar, "Design and implementation of traffic flow based street light control system with effective utilization of solar energy," *Int. J. Sci. Eng. Adv. Technol.*, vol. 3, no. 9, pp. 195-499, 2015.
 - 16) Bhuvanewari, R. Rajeswari and C. Kalaiarasan, "Analysis of solar energy based street light with auto tracking system," *Int. J. Adv. Res. Electr. Electron. Instrum. Eng.*, vol. 2, no. 7, pp. 3422-3428, 2013.
 - 17) K. Rath, "Arduino based: Smart light control system," *Int. J. Eng. Res. Gen. Sci.*, vol. 4, no. 2, pp. 784-790, 2016. [14] P. C. Cynthia, V. A. Raj and S. T. George, "Automatic street light control based on vehicle detection using arduino for power saving applications," *Int. J. Electron. Electr. Comput. Syst.*, vol. 6, no. 9, pp. 297-295, 2017.
 - 18) L. A Akinyemi¹, O. O Shoewu, N.T Makanjuola, A.A Ajasa and C.O Folorunso, "Design and development of an automated home control system using mobile phone," *World J. Control Sci. Eng.*, vol. 2, no. 1, pp.6-11, 2014.
 - 19) K. P. Shinde, "A low-cost home automation system based on power-line communication," *Int. J. Creative Res. Thoughts*, vol. 5, no. 3, pp. 20-24, 2017.
 - 20) P. C. Joshin, M. Joseph, S. James and V. Sasidhara, "Automation using power line communication with web based access," *Int. J. Adv. Res. Electr. Electron. Instrum. Eng.*, vol. 4, no. 1, pp. 229-234, 2015.
 - 21) K. H. S. D. Abhishek and K. Srikant, "Design of smart street lighting system," *Int. J. Adv. Eng.*, vol. 1, pp. 23-27, 2015.
 - 22) K. S. Sheela and S. Padmadevi, "Survey on street lighting system based on vehicle movements," *Int. J. Innovative Res. Sci. Eng. Technol.*, vol. 3, no. 2, pp. 9220-9225, 2014.
 - 23) Y. Chunjiang, "Development of a smart home control system based on mobile internet technology," *Int. J. Smart Home*, vol. 10, no. 3, pp. 293-300, 2016.
 - 24) R. Banerjee, "Solar tracking system," *Int. J. Sci. Res. Publ.*, vol. 5, no. 3, pp. 1-7, 2015.
 - 25) M. Srikanth and K. N. Sudhakar, "Zigbee based remote control automatic street light system," *Int. J. Eng. Sci. Comput.*, pp. 639-643, 2014.
 - 26) Chammmam, W. Nsibi and M. Nejib Nehdi, "Behaviour of a high-intensity discharge lamp fed by a high-frequency dimmable electronic ballast," *Sage J.*, vol. 49, no. 2, pp. 277-284, 2017.
 - 27) Iorkyaa, A. I. Richard and A. N. Amah, "The efficacy of light emitting diode (led) lamps used in rural communities of Nigeria," *Energy Environ. Res.*, vol. 2, no. 1, pp. 121-127, 2012.
 - 28) P. Mestry, I. Darekar, A. Adurkar and S. Ojha, "Vehicle movement based street lights with external light sensing," *Int. J. Adv. Res. Eng. Sci. Technol.*, vol. 4, no. 2, pp. 2394-2444, 2017.
 - 29) Yilmaz and G. Kılıçoğlu, "Resistance to change and ways of reducing resistance in educational organizations," *Int. Assoc. Social Sci. Res.*, vol. 1, pp. 14-21, 2013.

- 30) S. Escolar, J. Carretero, M. Marinescu and S. Chessa, "Estimating energy savings in smart street lighting by using an adaptive control system," *Int. J. Distrib. Sens. Networks*, vol. 10, no. 5, pp. 1-17, 2014.